



Water Management Technologies, Inc. • PO Box 66125 • Baton Rouge, LA 70896 USA
 Toll Free: 877.755.0026 • Phone: 225.755.0026 • Fax: 225.755.0995
 Web Page: W-M-T.com • Email: info@w-m-t.com

Standard features

- Low weight cast aluminum construction.
- Quiet operation with integral inlet and outlet muffling.
- Recognized TEFC motor.
- High efficiency / low noise impeller design.
- No lubrication / maintenance required.
- Allowed ambient: -10 °F to +105 °F.
- Mountable in any plane.

Max. continuous operating Pressure 4.6 psig / 127.0 In. WG
Vacuum 8.3 In. Hg / 112.8 In. WG

Options

- Remote drive models (belt or coupling).
- Special voltages.
- Surface treatment or plating.
- Gas tight sealing.
- Special designs available.

Accessories

- Inlet and/or inline filters.
- Additional inlet/outlet silencers.
- Safety valves.
- Flow converting devices.
- Optional connectors.



Dimensions in inches

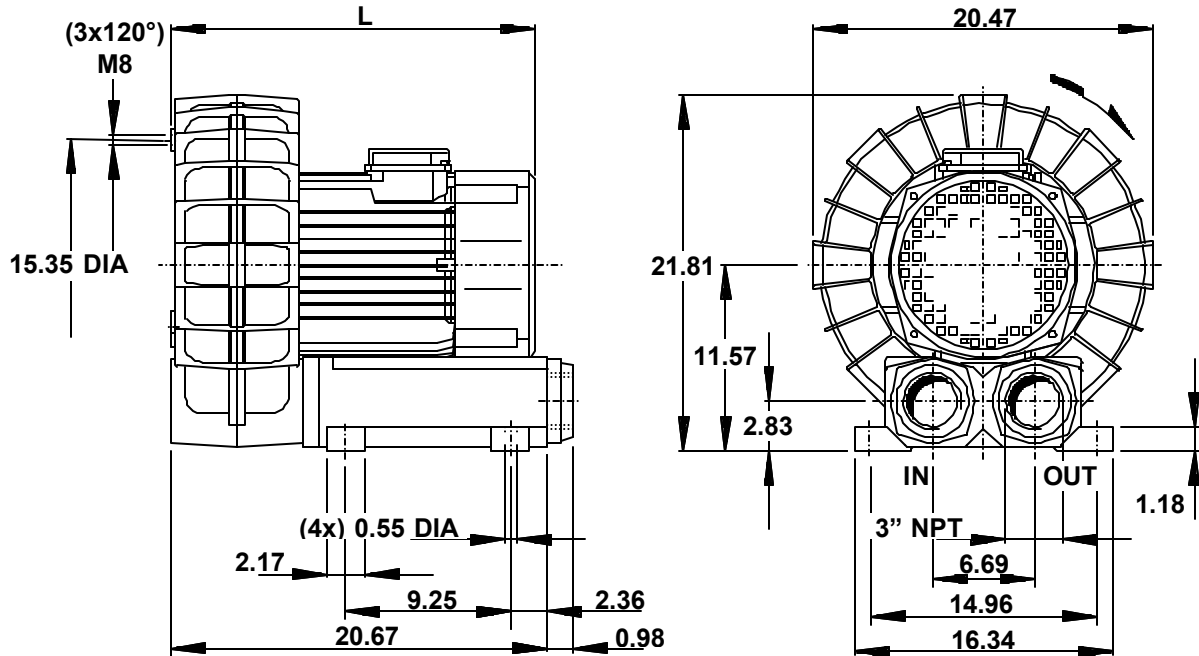

Motor power	Hp 60 Hz	5	7 1/2	10
	Hp 50 Hz	4 1/6	6 1/4	8 1/3
L	In.	18.50	20.28	20.28
Weight	Lbs.	129.80	151.80	166.10



REGENERATIVE BLOWERS - S70S

50 or 60 Hz • Single or Three Phase



Water Management Technologies, Inc. • PO Box 66125 • Baton Rouge, LA 70896 USA
 Toll Free: 877.755.0026 • Phone: 225.755.0026 • Fax: 225.755.0995
 Web Page: W-M-T.com • Email: info@w-m-t.com

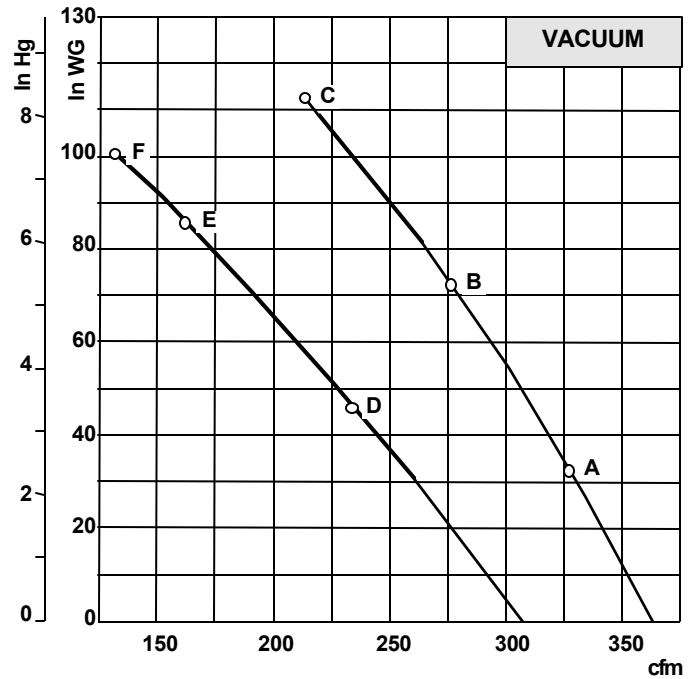
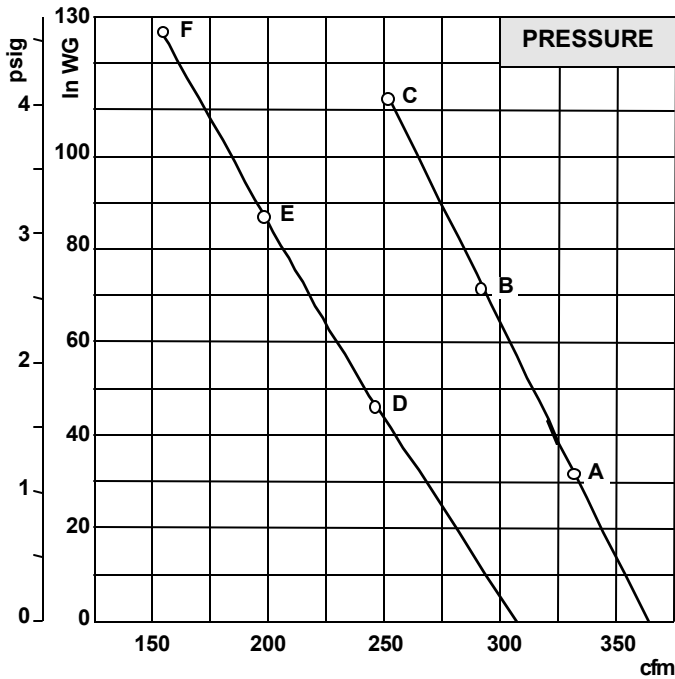

Notes:

- Curves indicate performance rated for continuous operation.
- Performance data based on ambient / inlet air temperature of 68 °F and barometric pressure of 29,92 In. Hg
- Performance values may vary by ±10%
- Sound level measured at 1 m distance with inlet and outlet piped.
- Specifications are subject to change without notice.

S70S

60 Hz – 3500 rpm

Reference		A	B	C
Maximum airflow	cfm	363	363	363
Maximum continuous pressure	In. WG	32	72	112
Maximum continuous vacuum	In. Hg	2.4	5.3	8.3
Maximum sound level	dB(A)	84	84	84
Motor horsepower	Hp	5	7 1/2	10
Standard voltage	Volt	208-230/460	208-230/460	208-230/460
Phase		3	3	3
Rated F.L. current	Amps	15,5-14,0/7,0	20,8-18,8/9,4	27,6-25,0/12,5
Rated locked rotor current	Amps	109-98/49	125-113/57	193-175/88
Insulation	Class	F	F	F

50 Hz – 2900 rpm

Reference		D	E	F
Maximum airflow	cfm	307	307	307
Maximum continuous pressure	In. WG	47	87	127
Maximum continuous vacuum	In. Hg	3.4	6.4	7.4
Maximum sound level	dB(A)	81	81	81
Motor horsepower	Hp	4 1/6	6 1/4	8 1/3
Standard voltage	Volt	200/400	200/400	200/400
Phase		3	3	3
Rated F.L. current	Amps	15,5/7,0	20,8/9,4	27,6/12,5
Rated locked rotor current	Amps	109/49	125/57	193/88
Insulation	Class	F	F	F